

FMM Fan Range Details

The "Finna **M**edium pressure **M**oulded" fan range is an injection moulded Forward Curve Centrifugal fan capable of producing moderate volumes with moderate pressures.

FMM duty range

- Volumes up to 13,500 m³/hr
- Pressures up to 2,600 Pa

FMM fan sizes range from

- 125 mm - 400 mm (Inlet)

Fan casing materials

- Polypropylene
- Fire Retardant Polypropylene
- UPVC
- UPVC/FRP
- PPSEL Anti - static, for Zone I and 2

Impeller materials

- UPVC
- Polypropylene
- PVDF

Steelwork

- Mild steel / galvanized as standard

Fixings

- A2 stainless steel minimum

Performance data

- In accordance with BS EN ISO 5801
- Category D test. Ducted inlet, ducted outlet
- Witness testing available upon request

FMM 125 - 400 Dimension Details

Dimensions

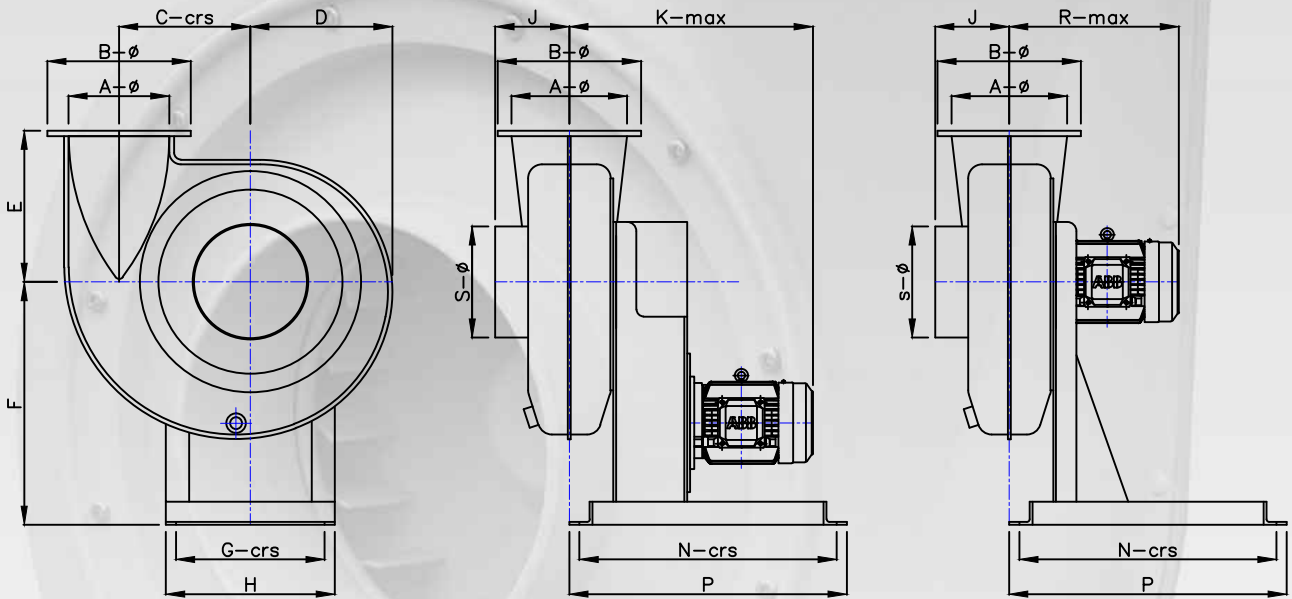

See page 3 for flange details

Drain threaded socket - 0.75" BSP std

4 off 10mm fixing holes

Dimension details

Fan Size	A	B	C	D	E	F	G	H	J	K	N	P	R	S
FMM 125	125	185	142	200	168	300	241	275	77	448	416	450	282	125
FMM 160	160	220	182	225	215	350	276	310	99	483	416	450	317	160
FMM 180	180	240	204	250	242	400	306	340	114	512	416	450	328	180
FMM 200	200	260	227	275	269	425	251	285	124	545	416	450	376	200
FMM 250	250	310	284	330	337	525	321	365	160	666	556	600	477	250
FMM 315	315	375	358	400	424	625	396	440	202	727	556	600	444	315
FMM 400	400	480	356	425	458	750	436	480	201	771	606	650	467	400

FMM 125 - 400 Outlet Flange Details

Dimensions

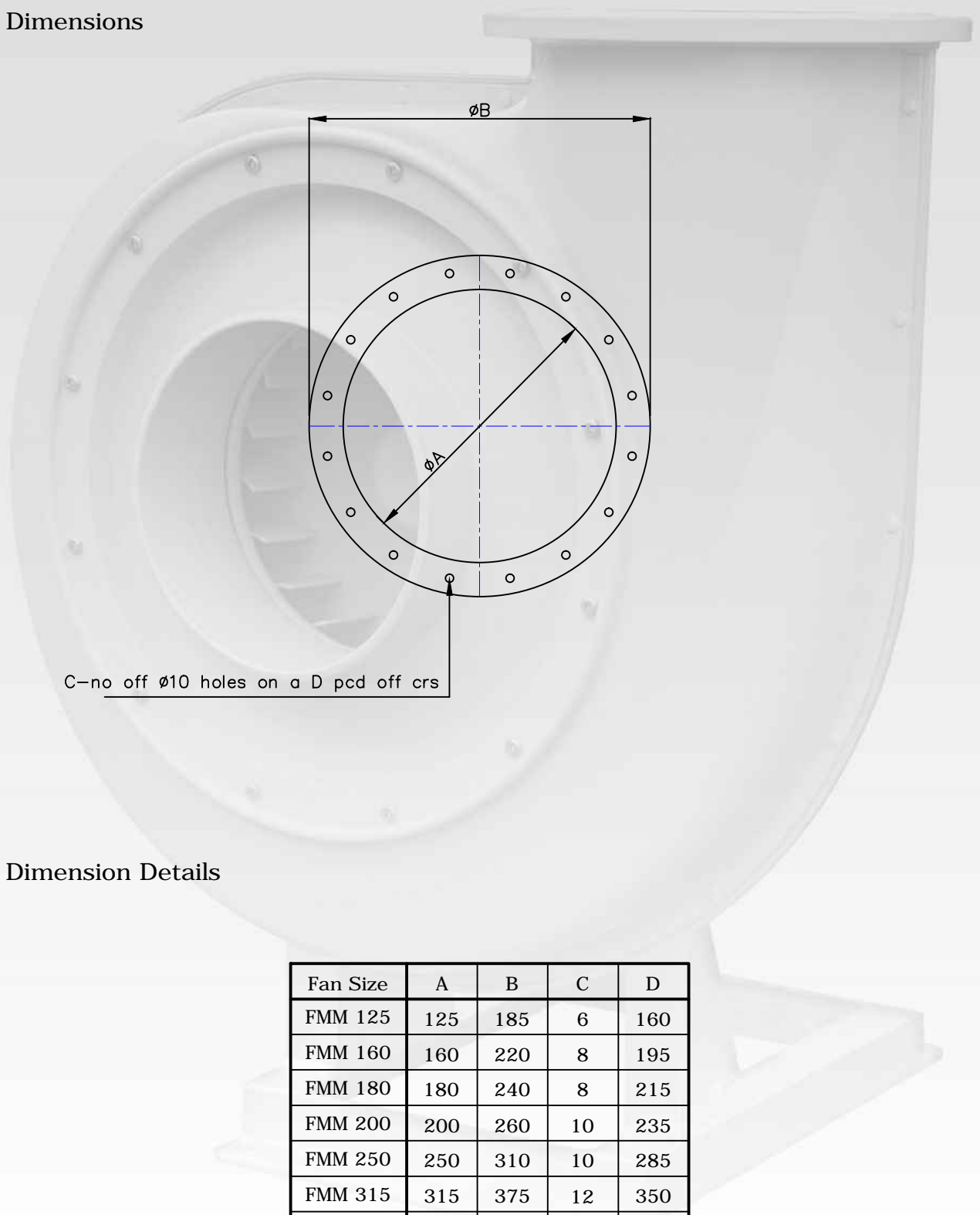

C-no off ø10 holes on a D pcd off crs

Dimension Details

Fan Size	A	B	C	D
FMM 125	125	185	6	160
FMM 160	160	220	8	195
FMM 180	180	240	8	215
FMM 200	200	260	10	235
FMM 250	250	310	10	285
FMM 315	315	375	12	350
FMM 400	400	480	18	445

FMM 125 Performance Curve

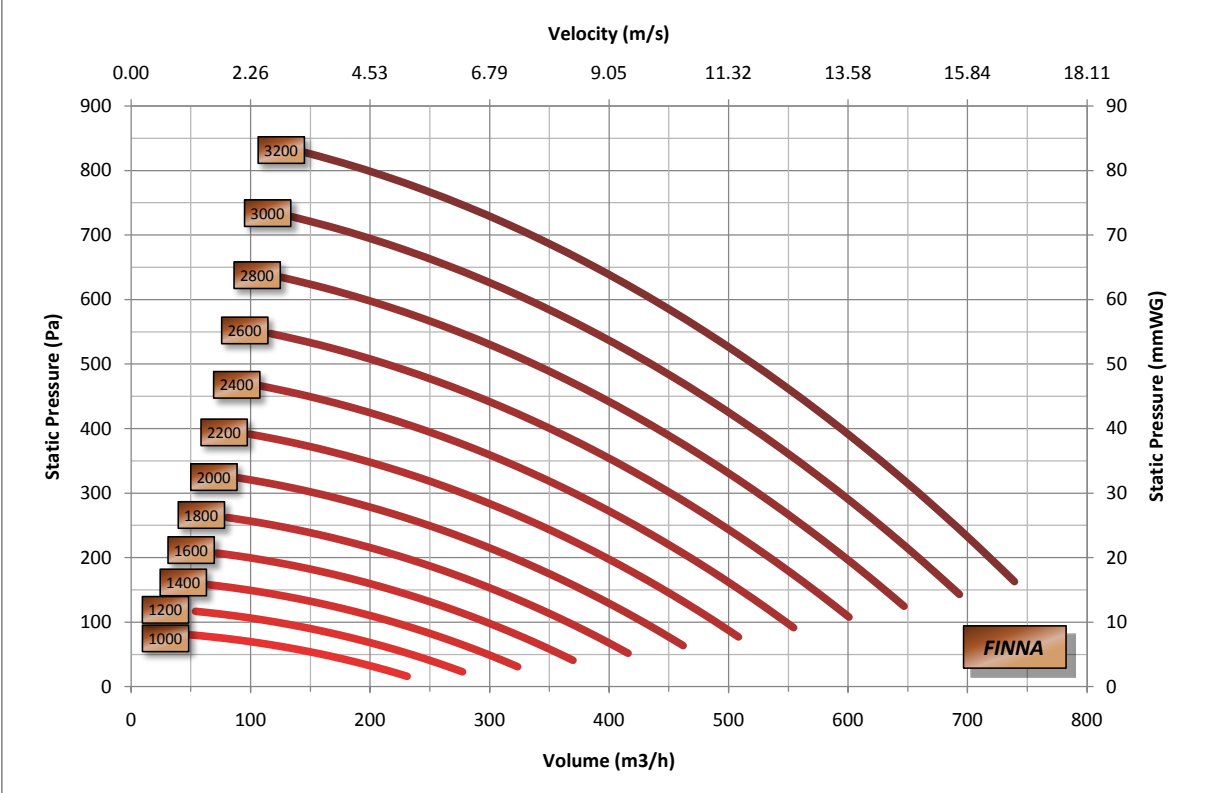

FMM 125 Power / Efficiency Curve

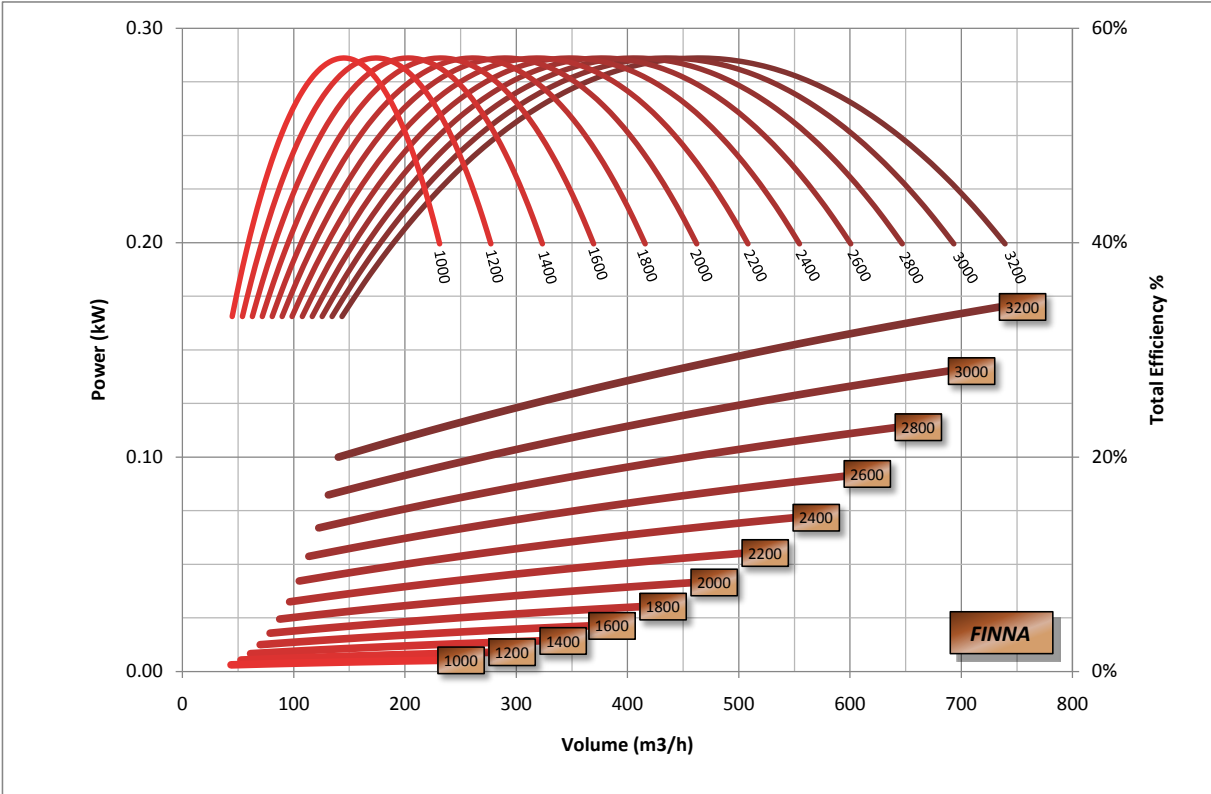

FMM 160 Performance Curve

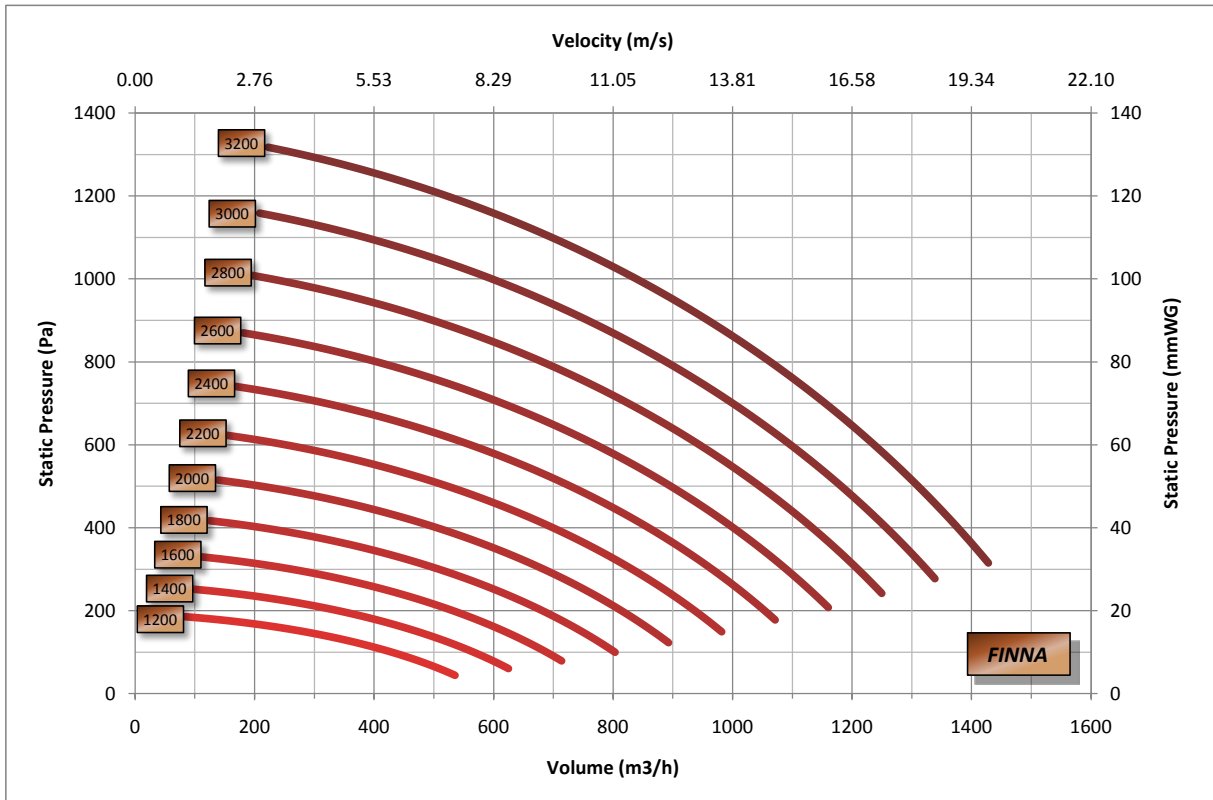

FMM 160 Power / Efficiency Curve

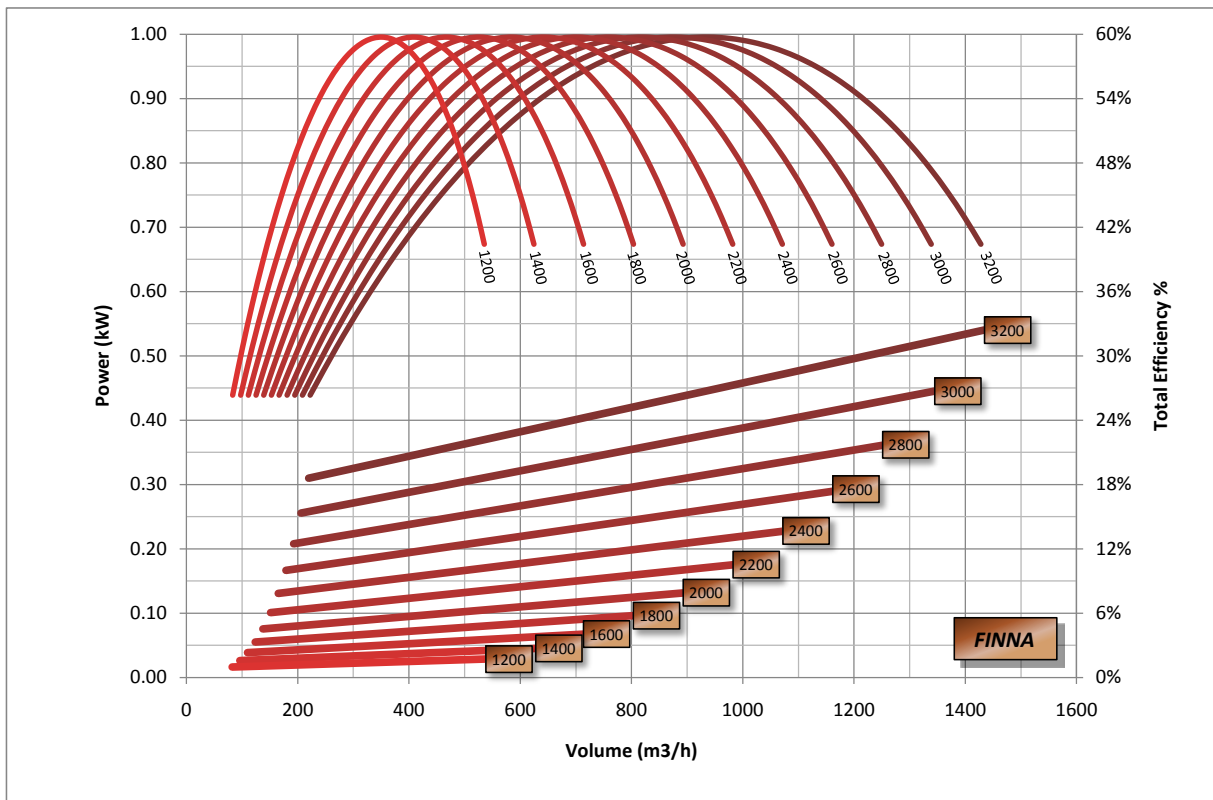

FMM 180 Performance Curve

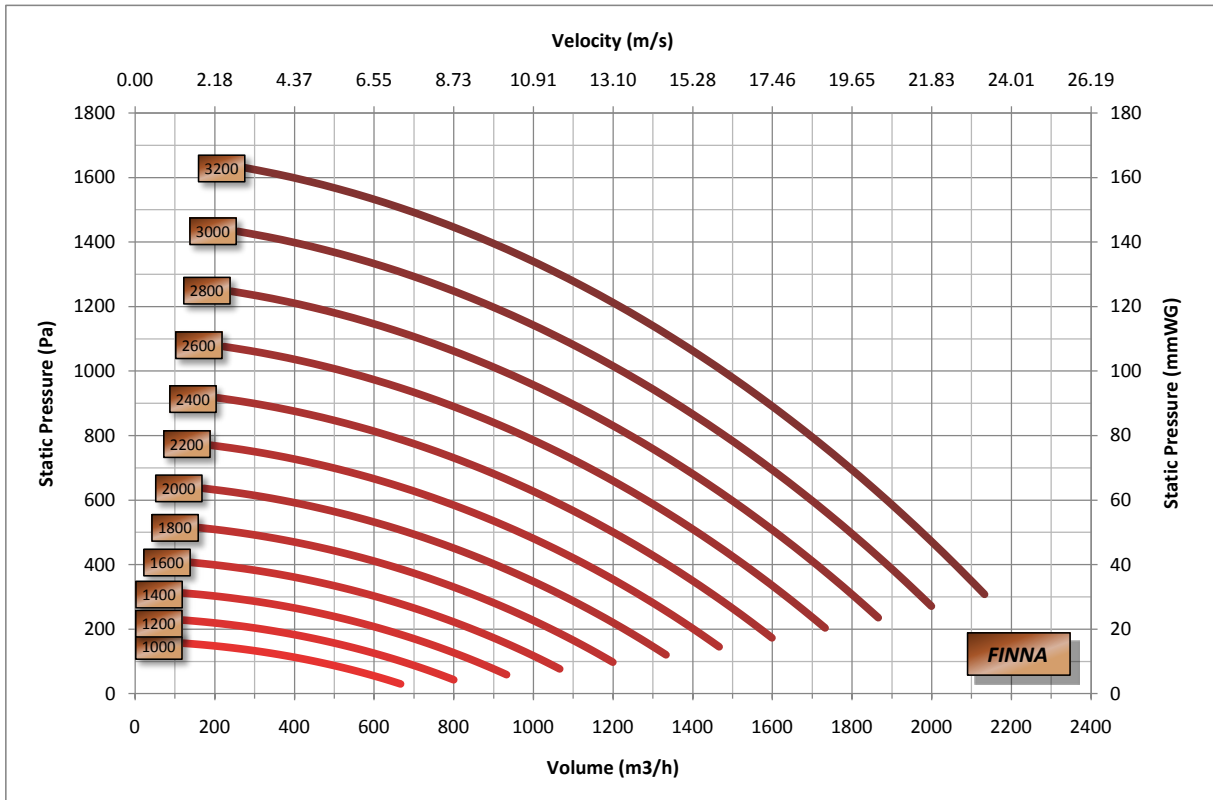

FMM 180 Power / Efficiency Curve

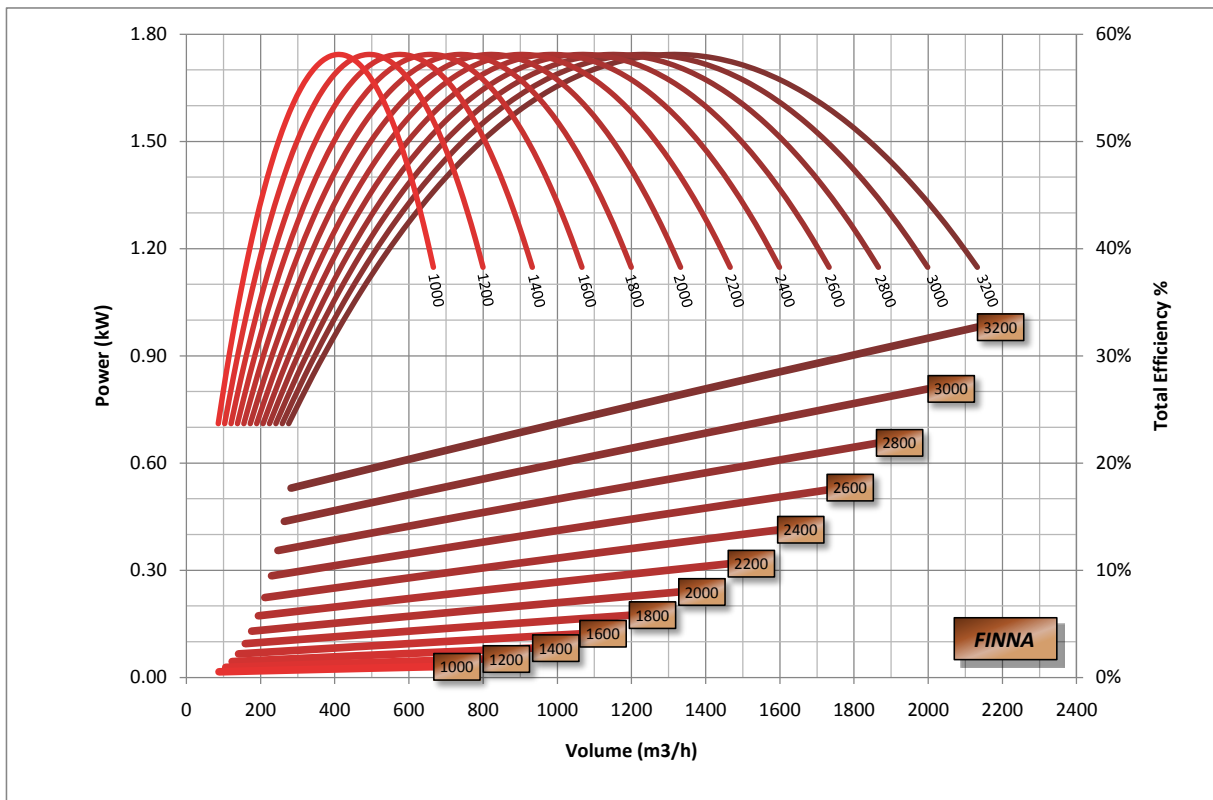

FMM 200 Performance Curve

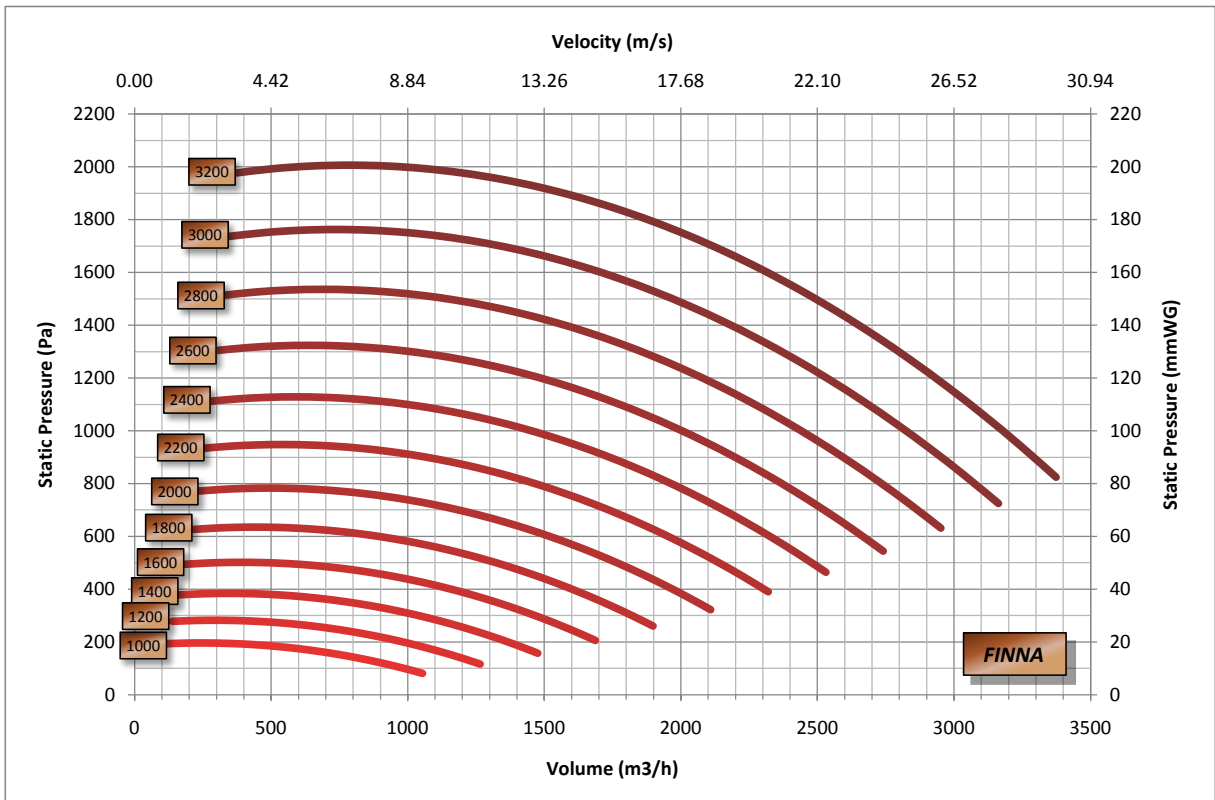

FMM 200 Power / Efficiency Curve

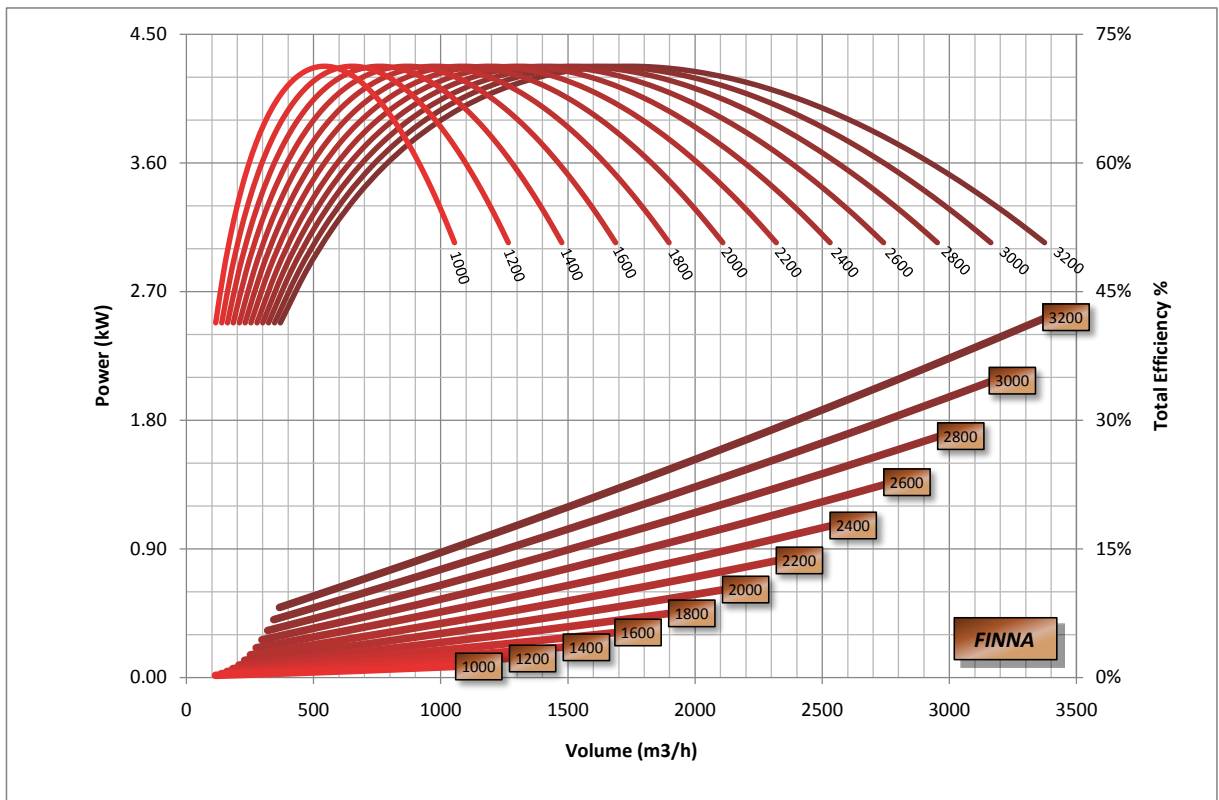

FMM 250 Performance Curve

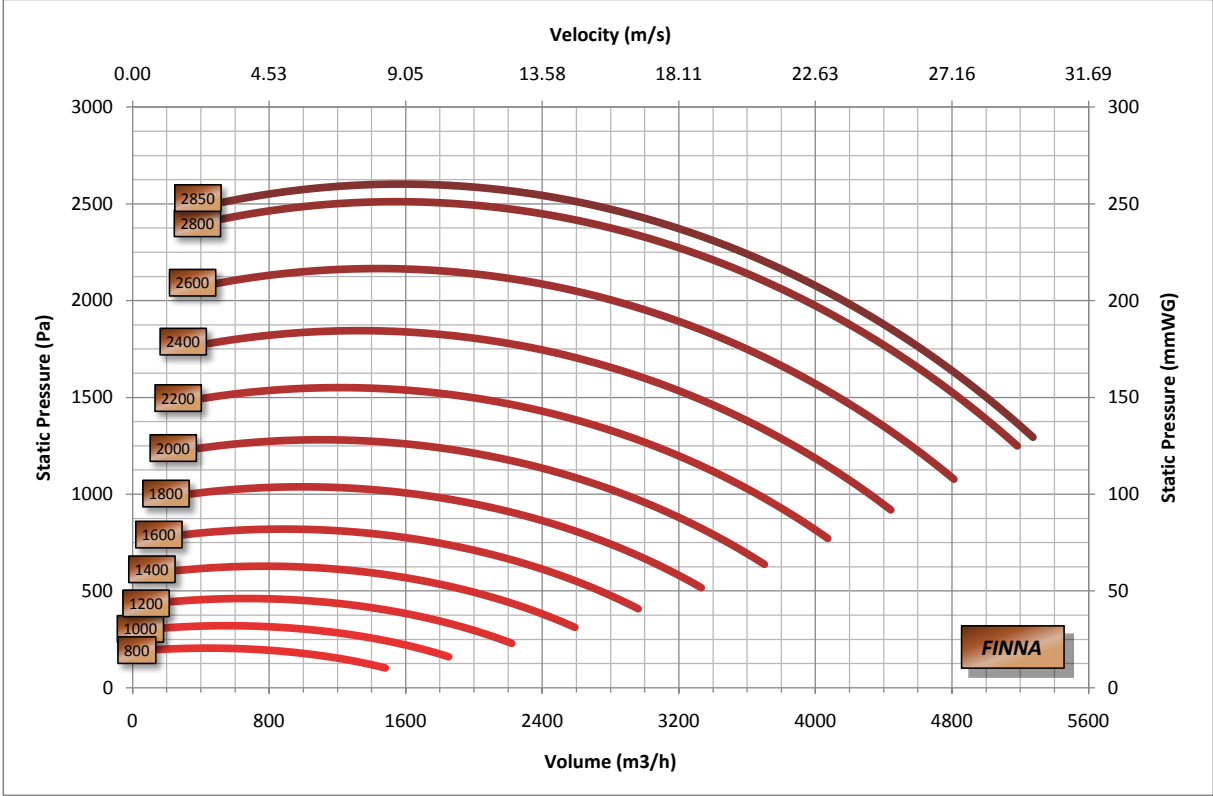

FMM 250 Power / Efficiency Curve

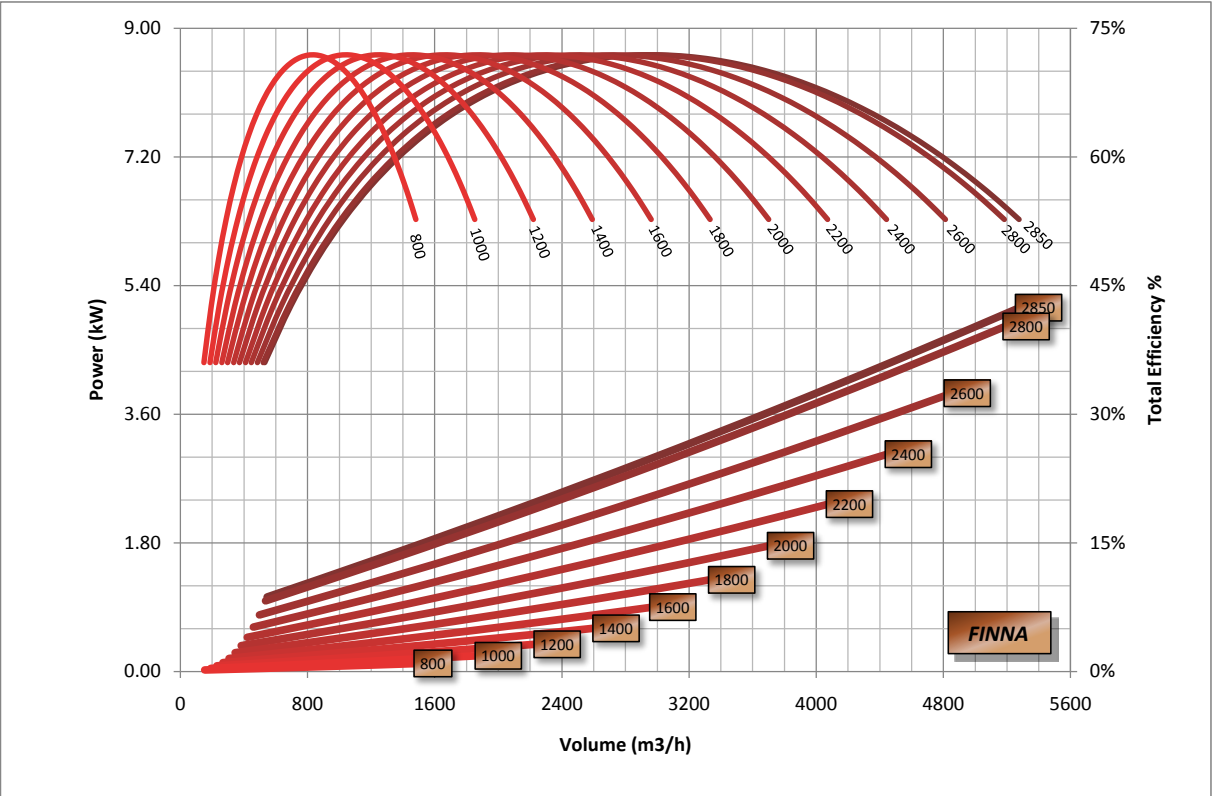

FMM 315 Performance Curve

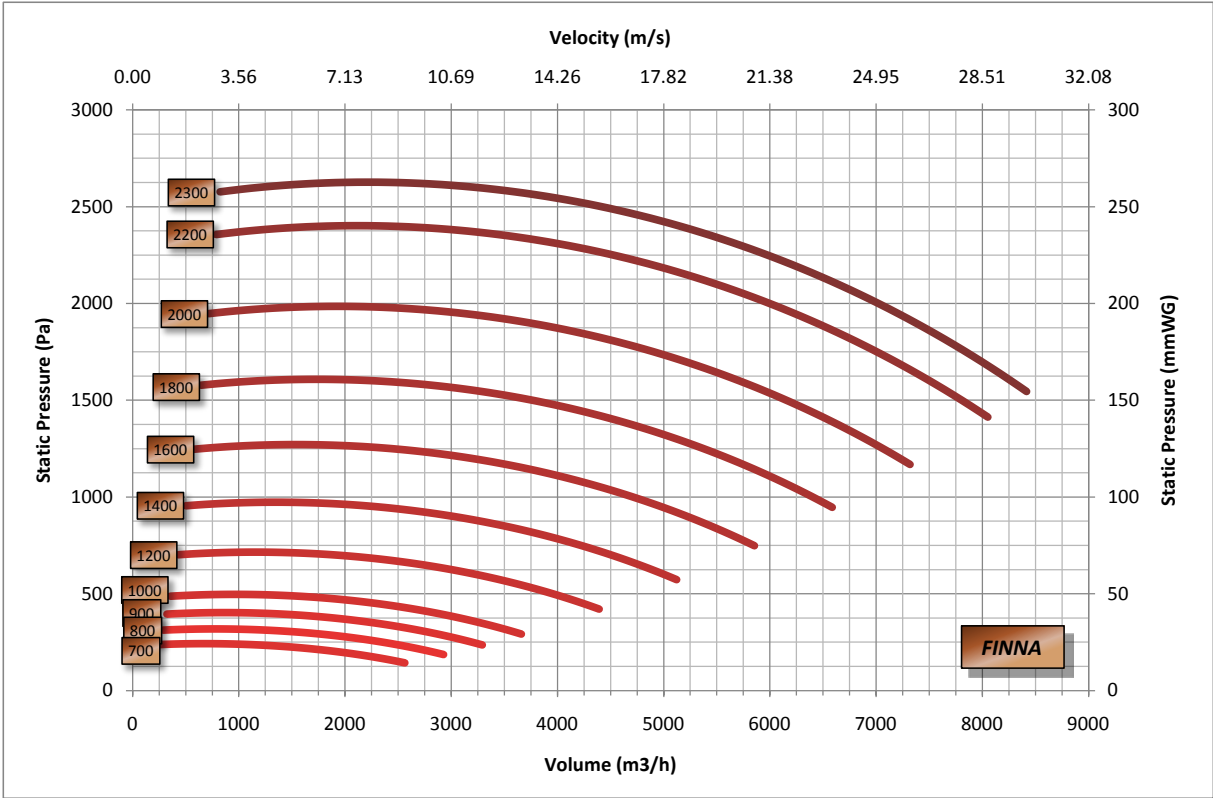

FMM 315 Power / Efficiency Curve

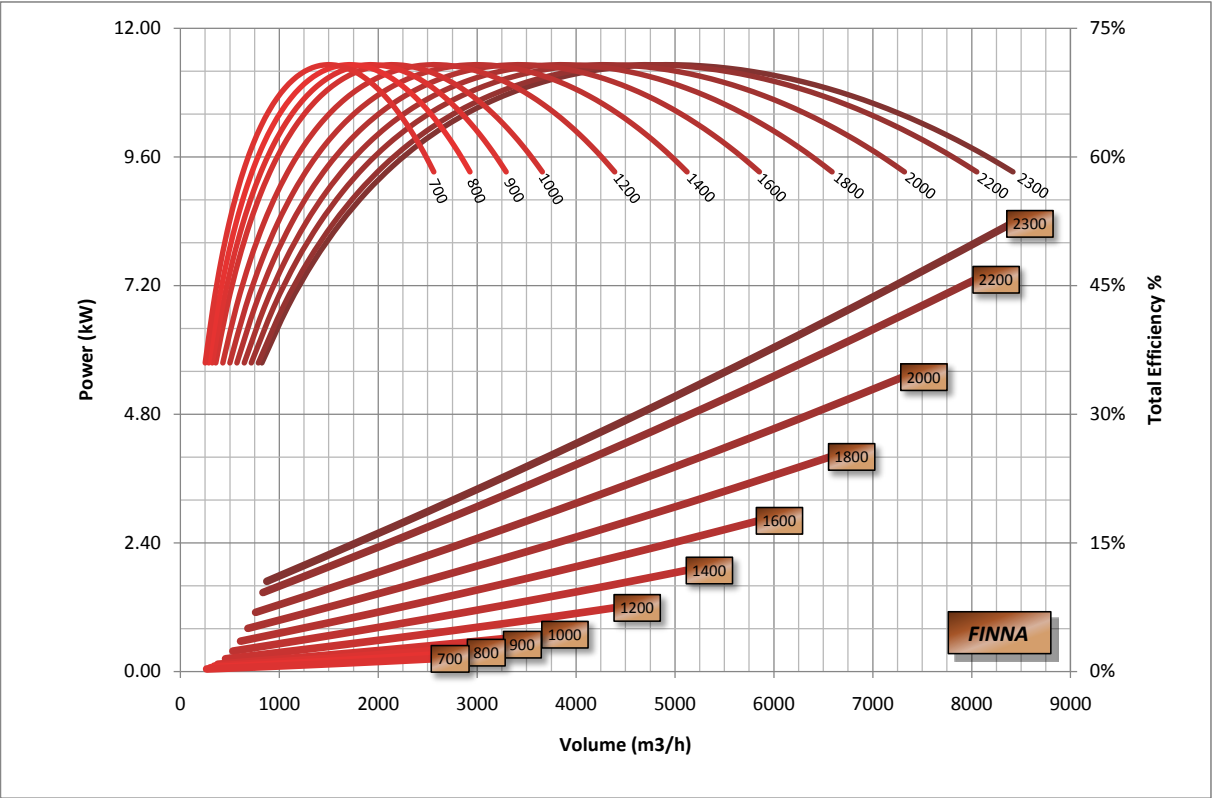

FMM 400 Performance Curve

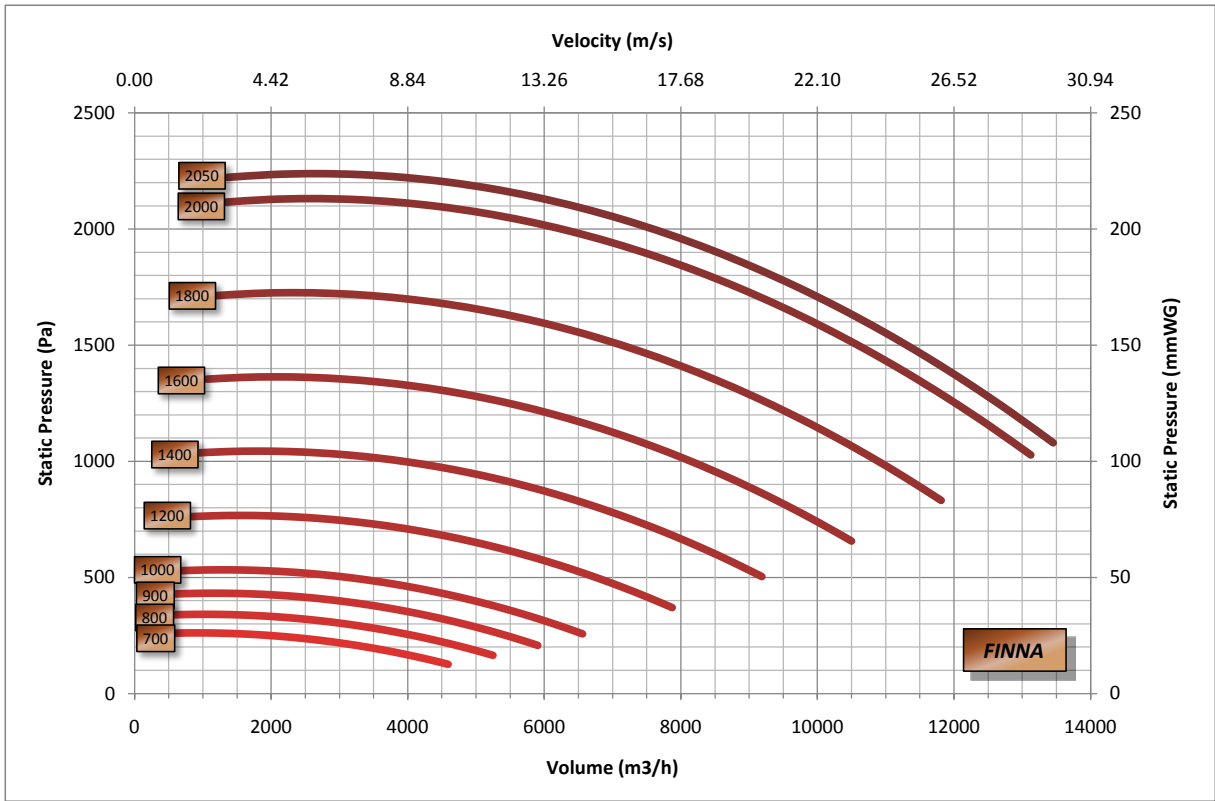

FMM 400 Power / Efficiency Curve

